

Broadband Optical Access Networks

Prof. Leonid Kazovsky

My Research Group: PNRL = Photonics and Networking Research Laboratory

Network Hierarchy

- Backbone:
 - Continent-to-Continent / Coast-to-Coast
 - Distances > 1000km
 - 10Gbit/s ~ Tbit/s
- Metro Core:
 - City-to-City
 - Distances ~ 100km
 - 1 Gbit/s ~ 40 Gbit/s
- Metro Access & Access
 - Within cities
 - Distances ~ 10km
 - 100 Kbit/s ~ 1 Gbit/s

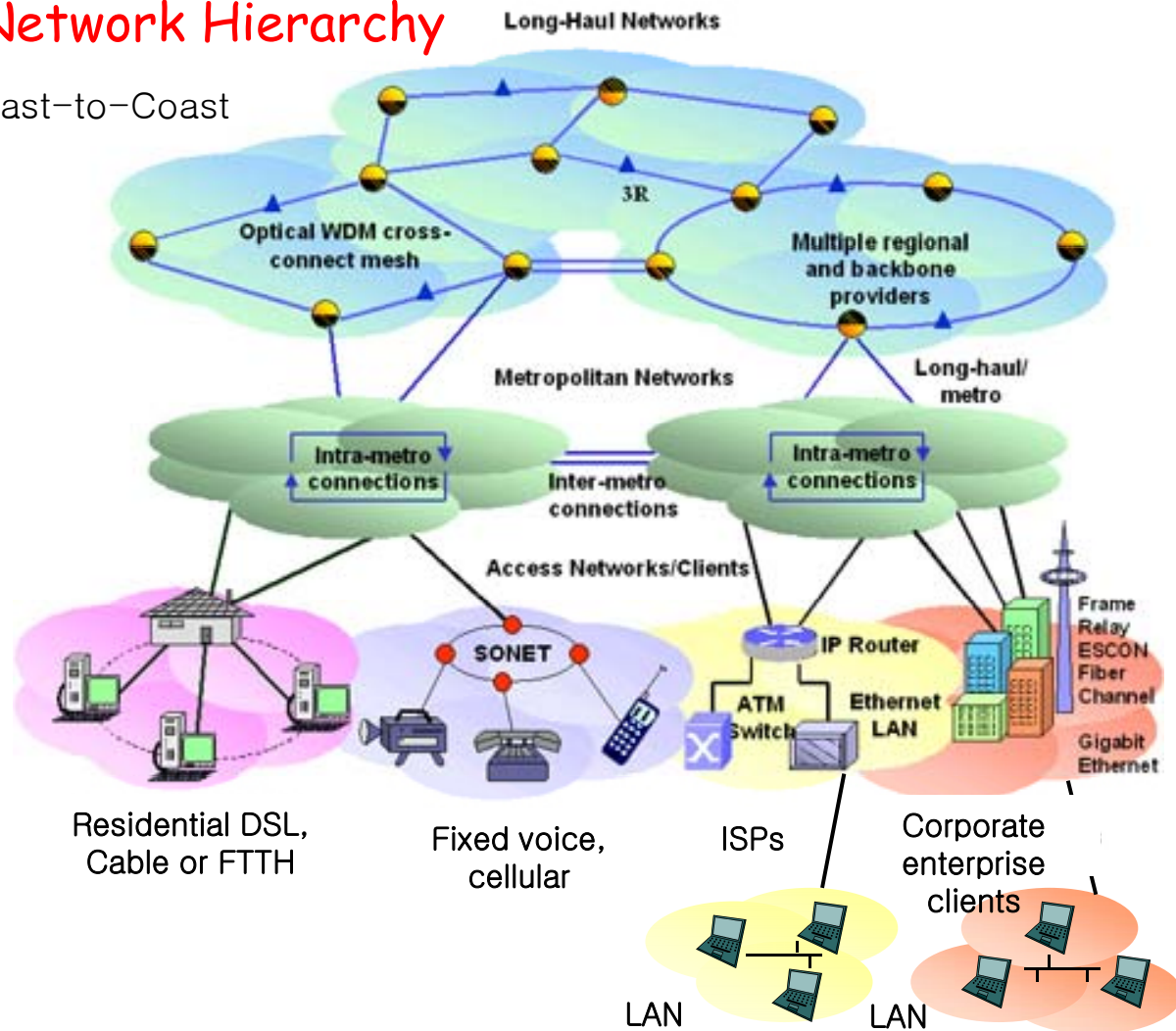

Motivation:

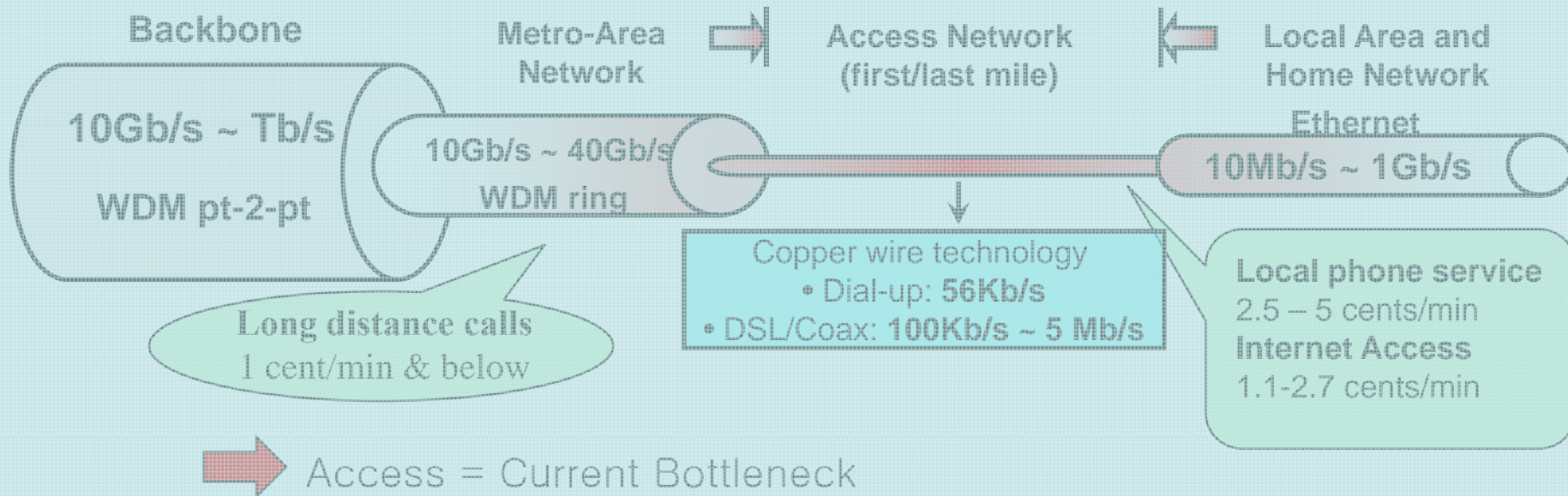

Access Technologies & Access Research at Stanford:

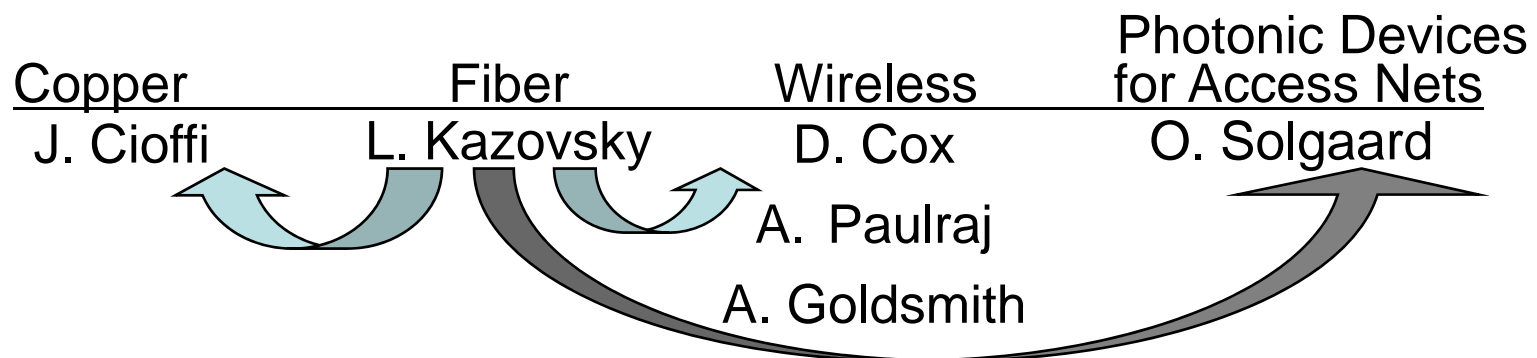

Optical Access : Main Challenges & Selected PNRL Projects

Challenge

- Need for energy efficient *and* adaptive optical access
- Integration with copper and wireless technologies
- Burst mode transmission at multiple bit rates
- Rapid change:
 - Higher bit rates, more wavelengths, more subscribers over the same infrastructure
- No security on optical level

PNRL Projects

- LEON[†]
- MARIN, GROW-Net
- NG-PON^{††}
- SUCCESS =
Stanford University ACCESS^{*}
- SureON^{*}

Broadband Optical Access Networks

- One technology: Passive Optical Networks, PONs

- Passive networks with tree topology
- High-bandwidth and low cost
- High reliability and easy maintenance
- Being deployed in 50% of US

- Current TDM PON standards

- BPON : ITU G.983
- GPON : ITU G.984
- EPON: IEEE 802.3ah

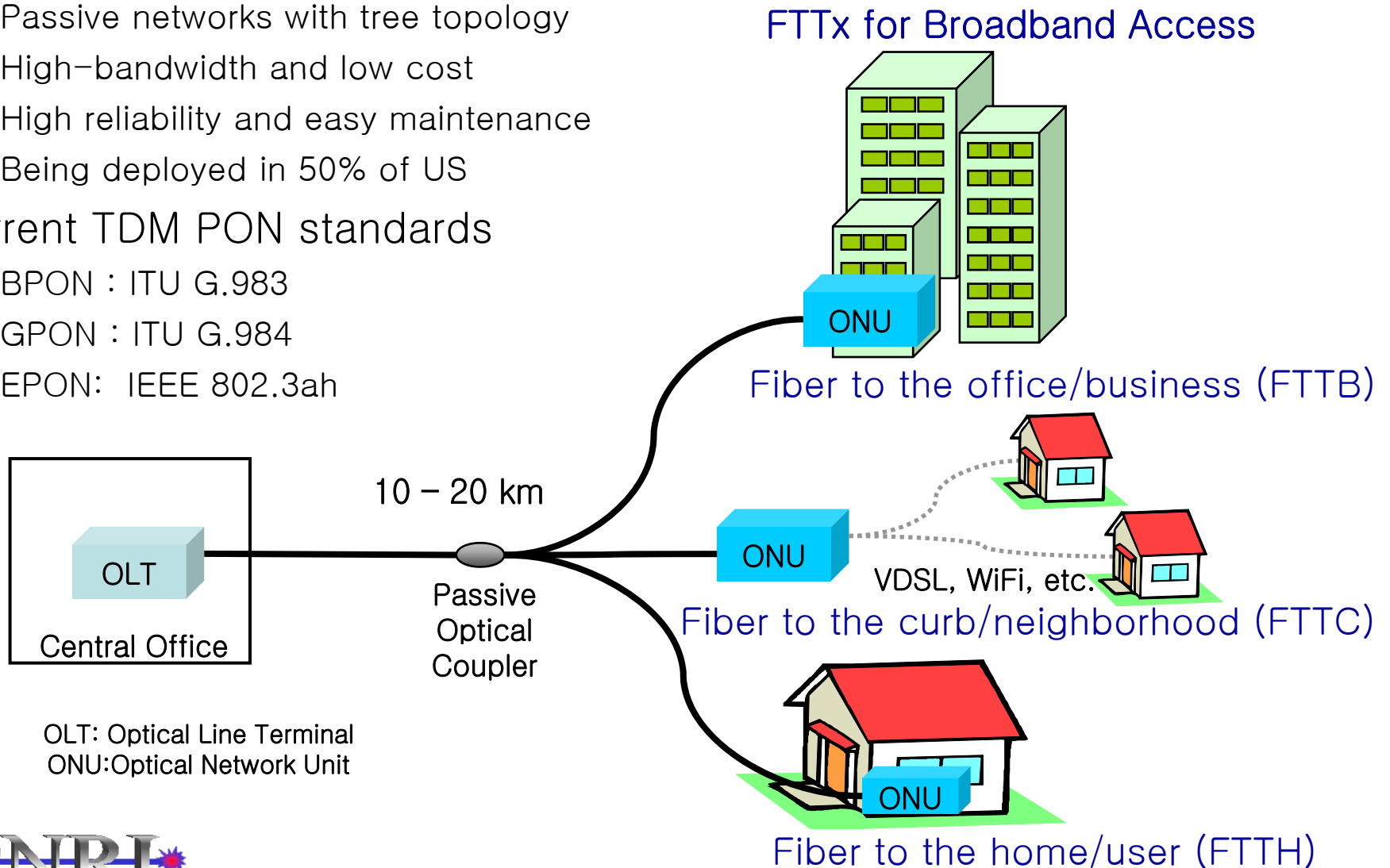

Selected PNRL Projects

1. SUCCESS-DWA

- SUCCESS-DWA
 - DWA = Dynamic Wavelength Allocation
 - Graceful evolution from TDM to WDM ...
- ... using
 - Novel architecture
 - Gradual addition of tunable lasers from 1 for N PONs to 1 for each subscriber
 - Novel use of AWG = Array Waveguide Grating (= passive optical router)

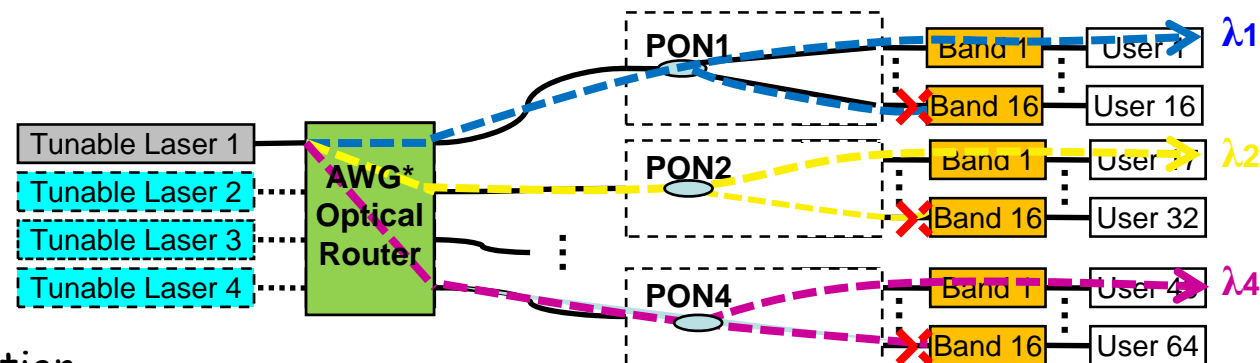

- Key features:
 - Graceful evolution
 - Statistical multiplexing gain
 - Cost sharing

Selected PNRL Projects

2. MARIN

- MARIN
 - MARIN = Metro and Access Ring Integrated Network
 - Integrated Optical Wireless Access Network
- Highly evolutionary architecture
 - Employs PON technology in the backhaul
 - Adaptive architecture using dynamic WDM

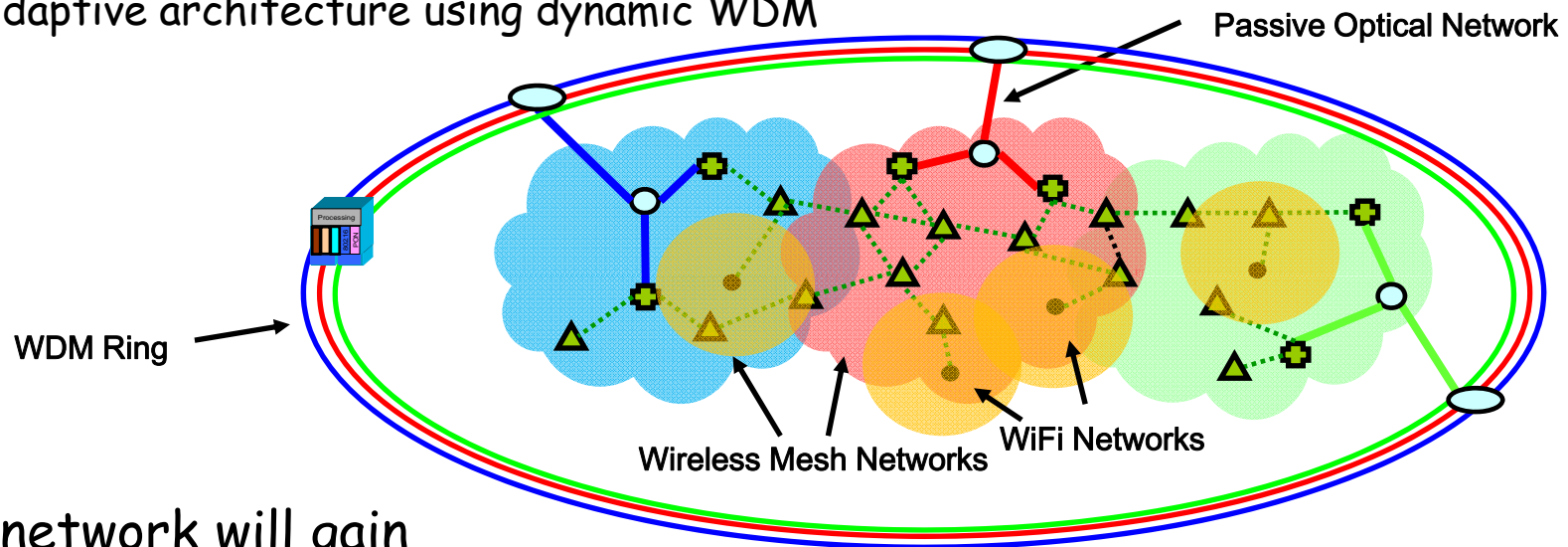

- The network will gain
 - Higher bit rate, better QoS, improved reliability

Selected PNRL Projects

3. LEON

- LEON
 - LEON = Latching Energy-Efficient Optical Node
 - Intelligent Optical Device to Reconfigure Access Network
 - Adapts from passive optical splitter to smart splitter to WDM router
 - Latching = nearly passive

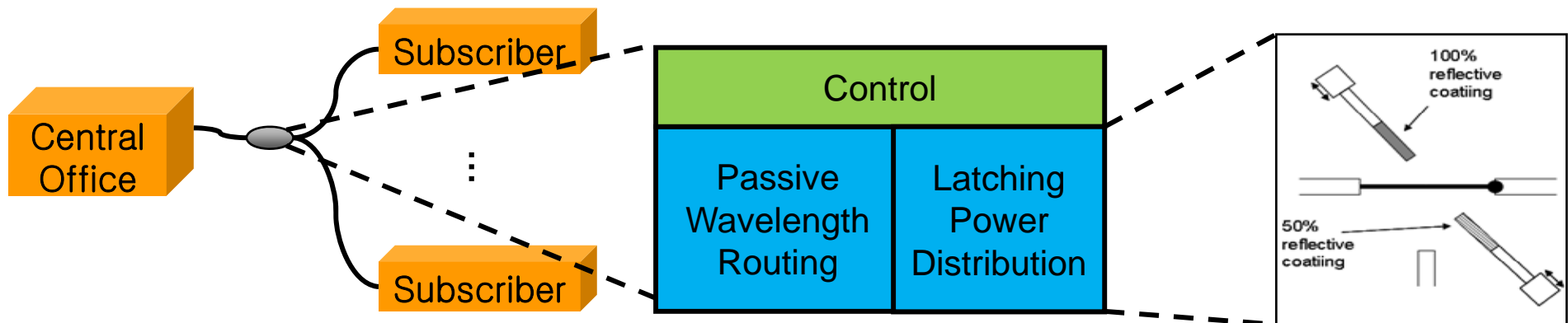

- The network will gain:
 - Protection against optical attacks
 - Graceful evolution from TDM to WDM
 - Smarter allocation of power and wavelength

Selected PNRL Projects

4. SUCCESS-LCO

- LCO
 - Add new service (e.g. 10Gbps) without disturbing old customers
 - LCO = Line Code Overlay

